

7R PLUS BEAM MOVING HEAD

USER MANUAL



Please read over this manual before operating the light

Chapter 1 Installation and attention

1.1 Maintenance

- To reduce the risk of electrical shock or fire, do not expose this unit to rain or moisture.
- Intermittently using will extend this item's service life.
- Please clear the fan, fan net, and optical lens in order to keep good work state.
- Do not use the alcohol or any other organic solvent to wipe the shell.

1.2 Statement

The product has perfect performance and integrity packing. All users should be strictly complying with the warning and operating instructions as stated. Or we aren't in charge of any result by misuse. Any damage resulting by misuse is not within the Company's warranty. Any fault or problem caused by neglecting the manual is also not in the charge of dealers.

Note: All information is subject to change without prior notice.

1.3 Safety Precaution

- In order to guarantee the product's life, please don't put it in the damp places or even the environment over 60 degree.
- Always mount this unit in safe and stable matter.
- Install or dismantle should be operated by professional engineer.
- Using lamp, the change rate of power voltage should be within $\pm 10\%$. If the voltage is too high, it will shorten the light's life; if it's not enough, will influence the effect.
- Please restart it 20 minutes later after turning off the light, until full-cooling. Frequent switching will reduce the life span of lamps and bulbs; intermittent using will improve the life of bulbs and lights.
- In order to make sure the product is used correctly, please read the Manual carefully.

1.4 Product Instruction

- Lamp: ROCCER 240W(WITH OSRAM BURNER)
- Channel mode: 18 DMX512 Channel
- Pan scan: 540°(16bit) Electric correction
- Tilt scan: 270° (16bit) Electric correction
- Amazing dot matrix, four tact switch, 180° turning show
- Color wheel: 14colors + white, and seven color effect;
- Gobo wheel: 14 gobos(8 fixed gobos + 5 glass gobos + white);
- Effect Wheel: 8 prism/8+16prism;
- 0-100% mechanical dimming, mechanical dimming and free dimming available.
- Strobe macro control available;
- Lens optical system alchemical force, beam angle 0~4°;
- Over-heat protection

- Power Input: 100-240V, 50/60Hz
- Power Dissipation: 400W
- IP level :IP20
- Magnetic ballast and AC/Dc power supply
- Product Size: 310×230×500mm
- Packing Size: 635X440X725
- Net weight: 14.5KG

1.5 Cable connection (DMX)

Use a cable conforming to specifications EIA RS-485: 2-pole twisted, shielded, 120Ohm characteristic impedance, 22-24 AWG, low capacity. Do not use microphone cable or other cable with characteristics differing from those specified. The end connections must be made using XLR type 3 or 5-pin male/female connectors. A terminating plug must be inserted into the last projector with a resistance of 120Ohm (minimum 1/4 W) between terminals 2 and 3.

IMPORTANT: The wires must not make contact with each other or with the metal casing of the connectors. The casing itself must be connected to the shield braid and to pin 1 of the connectors.

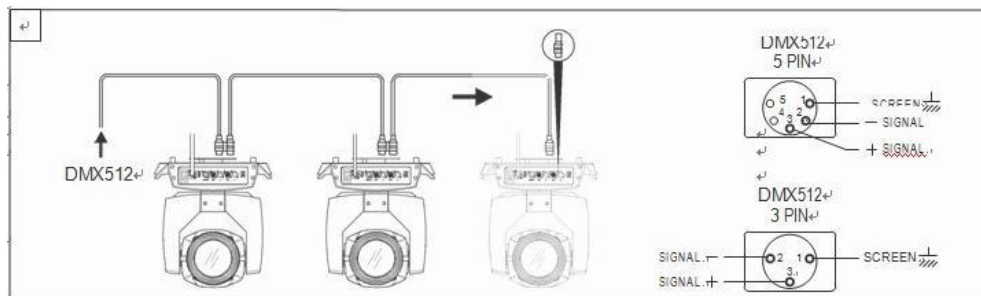

Figure 1 DMX Cable connection

1.6 Rigging (Optional)

This equipment can be positioned and fixed by clamp in every direction of the stage. Locking system makes it easy to fasten to the bracket.

Attention! Two clamps are needed to fix the equipment. Every clamp is locked by fastener of 1/4 kind. Fastener can only be locked clockwise.

Attention! Fasten a safety string to the additional hole of side aluminum piece. The secondary accessory could not hang on the delivery handle. Nip the equipment on bracket.

- Check if rigging clamp (not including the one inside) damaged or not? If stand ten times weight as the equipment. Make sure the architecture can stand ten times weight as all the equipment, clamps, wirings and other additional fixtures.
- Screws for clamping must be fixed firmly. Take one M12 screw (Grade 8.8 or higher) to clamp bracket, and then screw the nuts.
- Level the two hanging points at the bottom of clamp. Insert fastener to the bottom, lock the two levers by 1/4 rotating clockwise; then install another clamp.
- Install on safety string which stands at least ten times weight as equipment. Terminal of the

accessory is designed for clamps.

- Make sure pan/tilt lock unlocked or not. Keep the distance more than 1M from equipment to flammable material or lighting source.

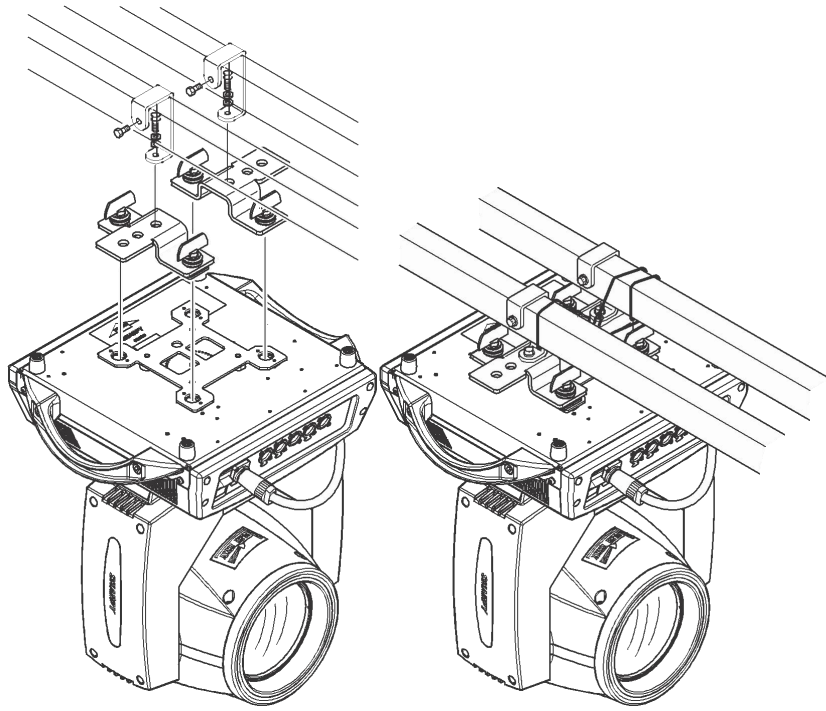

Figure 2 Installation

Chapter 2 Channel description

2.2 Channel Detail

TOP	LEVEL 1	LEVEL 2	LEVEL 3
DMX ADDRESS	001-512		
LAMP	LAMP CONTROL	DO NOTHING AND EXIT/OPEN LAMP/CLOSE LAMP	
	POWER ON LAMP ON	ON/ <u>OFF</u>	
	AFTER RESET LAMP ON	ON/ <u>OFF</u>	
	LAMP BY DMX CONTROL	<u>ON</u> /OFF	
SETTING	CHANNEL MODE	<u>18CH</u>	
	PAN TILT FEEDBACK	<u>ON</u> /OFF	
	PAN INVERT	ON/ <u>OFF</u>	
	TILT INVERT	ON/ <u>OFF</u>	
	SWAP PAN TILT	ON/ <u>OFF</u>	
	SOUND SENSITIVITY	1- <u>15</u> -30	
DISPLAY	LANGUAGE	ENGLISH/中文	
	DISPLAY INVERSE	YES/ <u>NO</u>	
	BACKLIGHT	PERMANENTLY ON/ <u>30S OFF</u>	
MANUALLY CONTROL	PAN	<u>0</u> -255	
	PAN FINE	<u>0</u> -255	
	TILT	<u>0</u> -255	
	TILT FINE	<u>0</u> -255	
	PAN&TILE SPEED	<u>0</u> -255	
	STROBE	<u>0</u> -255	
	DIMMER	<u>0</u> -255	
	GOBO	<u>0</u> -255	
	COLOR	<u>0</u> -255	

	FOCUS	0-255	
	PRISM 1	0-255	
	PRISM 1 ROTATE	0-255	
	PRISM 2	0-255	
	PRISM 2 ROTATE	0-255	
	FROST	0-255	
	MULTICOLOR	0-255	
AUTO MODE	MASTER AUTO RUN	RUNNING...*	
	ALONE AUTO RUN	RUNNING...*	
	MASTER SOUND RUN	RUNNING...*	
	ALONE SOUND RUN	RUNNING...*	
FACTORY DEFAULT	YES/NO		
INFORMATION	LAMP STATUS NOW	ON/OFF	
	SOFTWARE VERSION	Vx.x	
	RDM UID	xxx...	
	RESET INFO	X RASTER	
		Y RASTER	
		X HALL	
		Y HALL	
		FOCUS HALL	
		GOBO HALL	
		COLOR HALL	
RESET	YES/NO		
SEND PARAMETERS	YES/NO		

18CH	VALUE	FUNCTION
CH1	0-255	Pan
CH2	0-255	Pan fine
CH3	0-255	Tilt
CH4	0-255	Tilt fine
CH5	0-255	Pan/Tilt speed(fast to slow)
CH6	0-255	Dimmer 0-100%
CH7	0-5	Shutter close
	6-20	Shutter open
	21-70	Normal synchronous strobe(slow to fast)

	71-100	Not synchronous strobe(slow to fast)
	101-150	Sinewave strobe(slow to fast)
	151-190	Opening pulse strobe(slow to fast)
	191-230	Closing pulse strobe(slow to fast)
	231-255	Shutter open
CH8	0-10	No effect
	11-255	Frost 100%
CH9	0-5	Open(white)
	6-10	Open->Color 1
	11-15	Color 1
	16-20	Color 1->Color 2
	21-25	Color 2
	26-30	Color 2->Color 3
	31-35	Color 3
	36-40	Color 3->Color 4
	41-45	Color 4
	46-50	Color 4->Color 5
	51-55	Color 5
	56-60	Color 5->Color 6
	61-65	Color 6
	66-70	Color 6->Color 7
	71-75	Color 7
	76-80	Color 7->Color 8
	81-85	Color 8
	86-90	Color 8->Color 9
	91-95	Color 9
	96-100	Color 9->Color 10
	101-105	Color 10
	106-110	Color 10->Color 11
	111-115	Color 11
	116-120	Color 11->Color 12
	121-125	Color 12
	126-130	Color 12->Color 13
	131-135	Color 13
	136-140	Color 13->Color 14
	141-145	Color 14
	146-150	Color 14->Open
151-200	CW flow(slow to fast)	
201-205	Color wheel stop	
206-255	CCW flow(slow to fast)	
CH10	0-5	Open(white)
	6-10	Gobo 1
	11-15	Gobo 2
	16-20	Gobo 3
	21-25	Gobo 4
	26-30	Gobo 5
	31-35	Gobo 6

	36-40	Gobo 7
	41-45	Gobo 8
	46-50	Gobo 9
	51-55	Gobo 10
	56-60	Gobo 11
	61-65	Gobo 12
	66-70	Gobo 13
	71-90	Gobo 14
	91-97	Gobo1 shake(slow to fast)
	98-104	Gobo2 shake(slow to fast)
	105-111	Gobo3 shake(slow to fast)
	112-118	Gobo4 shake(slow to fast)
	119-125	Gobo5 shake(slow to fast)
	126-132	Gobo6 shake(slow to fast)
	133-139	Gobo7 shake(slow to fast)
	140-146	Gobo8 shake(slow to fast)
	147-153	Gobo9 shake(slow to fast)
	154-160	Gobo10 shake(slow to fast)
	161-167	Gobo11 shake(slow to fast)
	168-174	Gobo12 shake(slow to fast)
	175-181	Gobo13 shake(slow to fast)
	182-188	Gobo14 shake(slow to fast)
	189-195	Gobo14 shake(slow to fast)
	196-202	Gobo14 shake(slow to fast)
	203-209	Gobo14 shake(slow to fast)
	210-230	CW flow(slow to fast)
	231-234	Gobo wheel stop
	235-255	CCW flow(slow to fast)
CH11	0-120	No effect
	121-255	Color effect 100%(only valid when no frost)
CH12	0-10	Prism 1 off
	11-255	Prism 1 on
CH13	0-2	Prism stop rotate
	3-150	Prism angle 0-400
	151-200	Prism CW(slow to fast)
	201-205	Prism stop rotate
	206-255	Prism CCW(slow to fast)
CH14	0-10	Prism 2 off
	11-255	Prism 2 on
CH15	0-255	Reserved
CH16	0-255	Focus(From far to near)
CH17	0-99	Not valid
	100-105	Lamp off(at least5S)
	106-199	Not valid
	200-205	Lamp on(at least 5S)
	206-255	Not valid
CH18	0-250	Not valid

顶层菜单	第一级	第二级	第三级
地址码	001-512		
灯泡	灯泡控制	无操作并退出/打开灯泡/关闭灯泡	
	开机亮灯	开/关	
	复完位亮灯	开/关	
	灯泡受 DMX 控制	开/关	
参数设置	通道模式设置	18 通道	
	XY 纠错启用	开/关	
	X 轴反向	开/关	
	Y 轴反向	开/关	
	XY 轴交换	开/关	
	声控灵敏度	1-15-30(越大越灵敏)	
显示设置	语言	ENGLISH/中文	
	显示反向	是/否	
	背光设置	常开/30 秒关闭	
手动控制	X 轴	0-255	
	X 轴微调	0-255	
	Y 轴	0-255	
	Y 轴微调	0-255	
	XY 轴速度	0-255	
	频闪	0-255	
	调光	0-255	
	图案	0-255	
	颜色	0-255	
	调焦	0-255	
	棱镜 1	0-255	
	棱镜 1 自转	0-255	
	棱镜 2	0-255	
	棱镜 2 自转	0-255	
	雾化切入	0-255	
	七彩切入	0-255	
自走模式	主机内置自走	运行中...*	
	单机内置自走	运行中...*	
	主机声控自走	运行中...*	
	单机声控自走	运行中...*	
恢复出厂设置	是/否		
信息	当前灯泡状态	开/关	
	软件版本	Vx. x	
	RDM UID 码	xxx...	
	复位检测信息	X 轴光耦	
		Y 轴光耦	

		X 轴霍尔	
		Y 轴霍尔	
		调焦霍尔	
		图案霍尔	
		色盘霍尔	
复位	是/否		
发送本机参数	是/否		

18 通道	数值	功能
CH1	0-255	水平
CH2	0-255	水平微调
CH3	0-255	垂直
CH4	0-255	垂直微调
CH5	0-255	水平垂直速度，快到慢
CH6	0-255	调光，0~100%
CH7	0-5	闭光
	6-20	开光
	21-70	同步频闪慢到快
	71-100	异步频闪慢到快
	101-150	渐开渐关慢到快
	151-190	渐开快关慢到快
	191-230	渐关快开慢到快
	231-255	开光
CH8	0-10	无雾化
	11-255	雾化 100%
CH9	0-5	无色盘
	6-10	白光到色盘 1
	11-15	色盘 1
	16-20	色盘 1 到色盘 2
	21-25	色盘 2
	26-30	色盘 2 到色盘 3
	31-35	色盘 3
	36-40	色盘 3 到色盘 4
	41-45	色盘 4
	46-50	色盘 4 到色盘 5
	51-55	色盘 5
	56-60	色盘 5 到色盘 6
	61-65	色盘 6
	66-70	色盘 6 到色盘 7
	71-75	色盘 7
	76-80	色盘 7 到色盘 8
	81-85	色盘 8
	86-90	色盘 8 到色盘 9
	91-95	色盘 9
	96-100	色盘 9 到色盘 10
101-105	色盘 10	

	106-110	色盘 10 到色盘 11
	111-115	色盘 11
	116-120	色盘 11 到色盘 12
	121-125	色盘 12
	126-130	色盘 12 到色盘 13
	131-135	色盘 13
	136-140	色盘 13 到色盘 14
	141-145	色盘 13
	146-150	色盘 14 到白光
	151-200	正转慢到快
	201-205	停止
	206-255	反转慢到快
CH10	0-5	无图案
	6-10	图案 1
	11-15	图案 2
	16-20	图案 3
	21-25	图案 4
	26-30	图案 5
	31-35	图案 6
	36-40	图案 7
	41-45	图案 8
	46-50	图案 9
	51-55	图案 10
	56-60	图案 11
	61-65	图案 12
	66-70	图案 13
	71-90	图案 14
	91-97	图案 1 抖动慢到快
	98-104	图案 2 抖动慢到快
	105-111	图案 3 抖动慢到快
	112-118	图案 4 抖动慢到快
	119-125	图案 5 抖动慢到快
	126-132	图案 6 抖动慢到快
	133-139	图案 7 抖动慢到快
	140-146	图案 8 抖动慢到快
	147-153	图案 9 抖动慢到快
	154-160	图案 10 抖动慢到快
	161-167	图案 11 抖动慢到快
	168-174	图案 12 抖动慢到快
	175-181	图案 13 抖动慢到快
	182-188	图案 14 抖动慢到快
	189-195	图案 14 抖动慢到快
196-202	图案 14 抖动慢到快	
203-209	图案 14 抖动慢到快	
210-230	正转慢到快	
231-234	停止	
235-255	反转慢到快	

CH11	0-120	无七彩
	121-255	七彩 100% (当有雾化时七彩无效)
CH12	0-10	无棱镜 1
	11-255	棱镜 1 切入
CH13	0-2	棱镜自转停止
	3-150	棱镜角度 0-400 度
	151-200	棱镜正转慢到快
	201-205	棱镜自转停止
	206-255	棱镜反转慢到快
CH14	0-10	无棱镜 2
	11-255	棱镜 2 切入
CH15	0-255	保留, 无功能
CH16	0-255	调焦, 远到近
CH17	0-99	无
	100-105	灯泡关闭, 至少保持 5S
	106-199	无
	200-205	灯泡打开, 至少保持 5S
	206-255	无
CH18	0-250	无
	251-255	所有电机复位, 至少保持 5S