

12*4in1 40w bee eye moving head

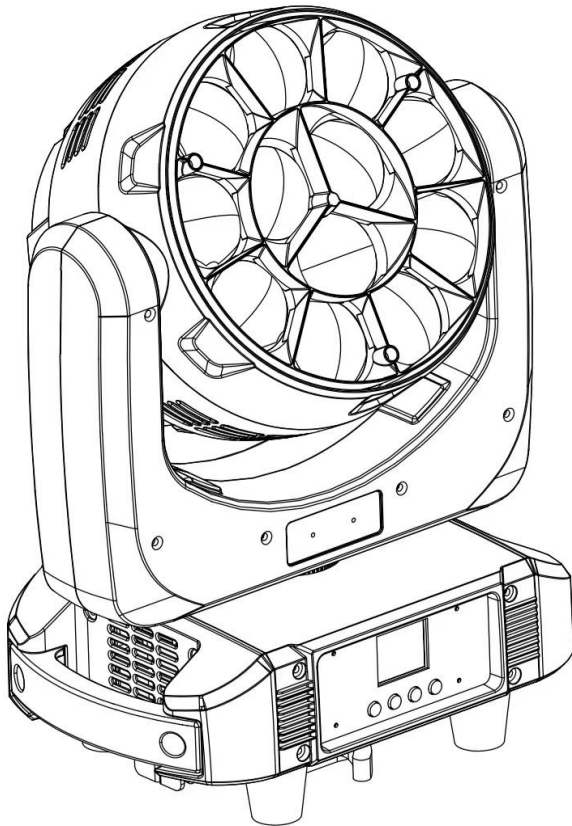

User manual

Please read the instructions carefully before use

TABLE OF CONTENTS

1. Safety Instructions	3-4
2. Technical Specifications	5
3. How To Control The Unit	6-12
4. shape	26
5. Trouble shooting	14
6. Fixture Cleaning	29

statement

The product has well capability and intact packing when leave factory. All of the user should comply with warning item and manual, any misuse cause of the damages are not included in our guarantee, and also can't be responsible for any malfunction & problem owing to ignore the manual.

1. Safety Instructions

Please keep this User Guide for future consultation. If you sell the unit to another user, be sure that they also receive this instruction booklet.

Unpack and check carefully there is no transportation damage before using the unit.

Before operating, ensure that the voltage and frequency of power supply match the power requirements of the unit.

It's important to ground the yellow/green conductor to earth in order to avoid electric shock.

The unit is for indoor use only. Use only in a dry location.

The unit must be installed in a location with adequate ventilation, at least 50cm from adjacent surfaces. Be sure that no ventilation slots are blocked.

Disconnect main power before replacement or servicing.

Make sure there are no flammable materials close to the unit while operating as it is fire hazard.

Use safety cable when fixes this unit. Do not handle the unit by taking its head only, but always by taking its base.

Maximum ambient temperature is T_a : 40°C. Do not operate it where the temperature is higher than this Unit surface temperature may reach up to 85°C. Do not touch the housing bare-hand during its operation. Turn off the power and allow about 15 minutes for the unit to cool down before replacing or serving.

In the event of serious operating problem, stop using the unit immediately. Never try to repair the unit by yourself. Repairs carried out by unskilled people can lead to damage or malfunction. Please contact the nearest authorized technical assistance center. Always use the same type spare parts.

Do not touch any wire during operation as high voltage might be causing electric shock.

Warning:

To prevent or reduce the risk of electrical shock or fire, do not expose the unit to rain or moisture.

Do not open the unit within five minutes after switching off.

The housing, the lenses, or the ultraviolet filter must be replaced if they are

visibly damaged.

Caution:

There are no user serviceable parts inside the unit. Do not open the housing or attempt any repairs yourself. In the unlikely event your unit may require service, please contact your nearest dealer.

Installation:

The unit should be mounted via its screw holes on the bracket. Always ensure that the unit is firmly fixed to avoid vibration and slipping while operating. And make sure that the structure to which you are attaching the unit is secure and is able to support a weight of 10 times of the unit's weight. Also always use a safety cable that can hold 12 times of the weight of the unit when installing the fixture.

The equipment must be fixed by professionals. And it must be fixed at a place where is out of the touch of people.

2. Technical Specifications

Light Sources: 12 x 40W 4in1 RGBW LED

Beam Angle: 3.5°~ 45°

Power Consumption: 400W

Power Voltage: AC 100-240V, 50/60Hz

Dimension: 324x240x377mm

Net Weight: 9.5Kgs

Packing size: 400x310x430mm

Control

DMX Channel: 21/25/33/81 Channel

Control Modes: DMX512/master-Slave/Auto Run/Music

Pan/Tilt

Pan/Tilt: 540° or 360° in optional / 270°

Pan/Tilt Resolution: 8/16 bit

Construction

Display: 1.8 TFT colorful Display

Data In/Out socket: 3-pin & 5-pin XLR sockets

Power Socket: Power Con in/out

Protection Rating: IP20

Features

LED single control, can display arrows, numbers, letters and patterns

High-efficiency optical system

Outstanding color macro effect

Dimmer: 0~100% smooth dimming

Variable strobe effects

Fast, quiet operation and flicker free

3. How To Control The Unit

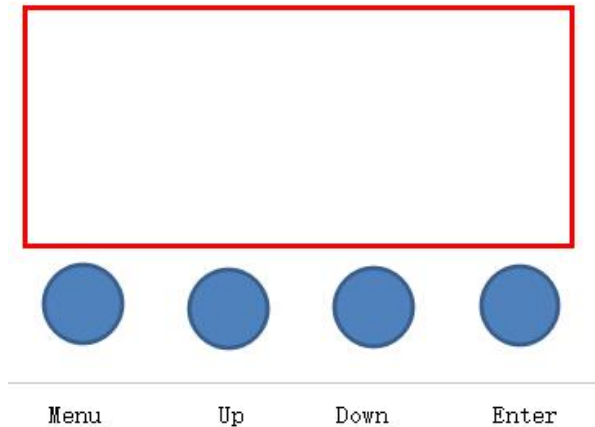

Display:

MENU	To select the programming functions
DOWN	To go backward in the selected functions
UP	To go forward in the selected functions
ENTER	To confirm the selected functions

Set DMX Address Code

- 1 Press "**Menu**" to "Set DMX Address", and press "**ENTER**" keys to enter into
- 2 Show "Set DMX Address DMX Address:001", Press the "**UP and DOWN**" keys to amended
- 3 Press "**ENTER**" keys to save and Exit, Press the "**MENU**" Keys does not save and Exit

Menu	1.Pan Degree	1.540		
		2.360		
	2.Mic Sense	001--100	Sound control adjust sensitiveness	
	3.Language	1.English		
		2.Chinese		
	4.No Signal	1.Black Out		
		2.Hold		
	5. Fan Set	1. Auto		
		2. Low		
		3. High		
	6.Reset	1.Yes		
		2.No		
	9.Default	1.Yes		
		2.No		
	10.Adjust	Pass Word	****	
		1.Pan	Pan fine-adjust	
		2.Tilt	Tilt fine-adjust	
		3.Focus	Zoom fine-adjust	
		4.Rota: 0-255	Rota fine-adjust	
5.Red		Change the value, adjust the white balance		
6.Green				
7.Blue				
8.White				
Address	Set address code 001--512			
Reverse	1.Pan	1.Yes		

		2.No		
	2.Tilt	1.Yes		
		2.No		
	3.Display	1.Yes		
		2.No		
Inform	1.CH Value		display all channel values	
	2.Temp/°C		display led board temperature	
	3.Soft v.xxx		software version number	
Mode	1.DMX512			
	2.Auto	1.Master		
		2.Alone		
	3.Sound	1.Master		
		2.Alone		
	4.Manual	Master	1.Pan:0--255	
			2.Tilt:0--255	
			3.Focus) :0--255	
			4.Rota:0-255	
			5.Red: 0--255	
		Alone	6.Greed: 0--255	
			7.Bule: 0--255	
8.White: 0--255				
9. Strobe: 0-255				
Channel	1.21Channels			

	2.25Channels
	3.33Channels
	4.81Channels

DMX channel's functions and values (21/25/35/81DMX channels):

Model 1 – CH21

Channel	Display	Function	Value
CH-1	Red	From dark to bright	0 --- 255
CH-2	Red fine	Red fine adjustment	0 --- 255
CH-3	Green	From dark to bright	0 --- 255
CH-4	Green fine	Green fine adjustment	0 --- 255
CH-5	Blue	From dark to bright	0 --- 255
CH-6	Blue fine	Blue fine adjustment	0 --- 255
CH-7	White	From dark to bright	0 --- 255
CH-8	White fine	White fine adjustment	0 --- 255
CH-9		No function	0----15
		R 100%, G up, B0%	16----35
		R down, G 100%, B0%	36----55

Color Temperature		R 0%, G 100%, B up	56----75
		R 0%, G down, B 100%	76----95
		R up, G 0%, B100%	96----115
		R 100%, G 0%, B down	116----135
		R 100%, G up, B up	136----155
		R down, G down, B 100%	156----175
		R100%G100%B100%W100 %	176----195
		2800K	196----200
		3200K	201----205
		4000K	206----210
		4500K	211----215
		5000K	216----220
		5600K	221----225
		6500K	226----230
		7000K	231----235
		7500K	236----240
		8000K	241----255
CH-10	Macro Color	No function	0 --- 19
		Effect -1	10--19
		Effect -2	20--29

		10 numbers 1 effect
		Effect -24	240--249
		Effect -25	250 --- 255
CH-11	Dimming	From dark to bright	0 --- 255
CH-12	Dimming adjustment	Dimming fine adjustment	0 --- 255
CH-13	Strobe	Turn on the light	0 --- 3
		From slow to fast	4 --- 203
		Random strobe	204 --- 255
CH-14	Pan	Pan control	0 --- 255
CH-15	Pan adjustment	Pan fine adjustment	0 --- 255
CH-16	Tilt	Tilt control	0 --- 255
CH-17	Tilt adjustment	Tilt fine adjustment	0 --- 255
CH-18	Zoom	Zoom	0-255
CH-19	Lens rotation	0~60°	0-155
		Clockwise infinite rotation	156-205
		Counterclockwise rotation	206-255
CH-20	Dimming Mode	Mode -1	0 --- 49
		Mode -2	50 --- 99
		Mode -3	100---149
		Mode -4	150---255

CH-21	Reset	NO function	0-250
		Reset within 5s	251---255

Model 2 – CH25

Channel	Display	Function	Value
CH-1	Pan	Pan control	0 --- 255
CH-2	Pan adjustment	Pan fine adjustment	0 --- 255
CH-3	Tilt	Tilt control	0 --- 255
CH-4	Tilt adjustment	Tilt fine adjustment	0 --- 255
CH-5	Pan/Tilt speed	Speed from fast to slow	0 --- 255
CH-6	Zoom	Angle from small to large	0 --- 255
CH-7	Lens rotation	0~60°	0-155
		Clockwise infinite rotation from fast to slow	156-205
		Counterclockwise rotation from slow to fast	206-255
CH-8	Dimmer	dark to bright linear dimming	0 --- 255
CH-9	Strobe	Turn on the light	0---3
		Synchro strobe speed From slow to fast (1HZ-25HZ)	4---203

		Random strobe	204--255
CH-10	R dimming	dark to bright linear dimming	0-255
CH-11	G dimming	dark to bright linear dimming	0-255
CH-12	B dimming	dark to bright linear dimming	0-255
CH-13	W dimming	dark to bright linear dimming	0-255
CH-14	Color temperature	No funtion	0 ---15
		R 100%, G up, B0%	16---35
		R down, G 100%, B0%	36---55
		R 0%, G 100%, B up	56---75
		R 0%, G down, B 100%	76---95
		R up, G 0%, B100%	96---115
		R 100%, G 0%, B down	116---135
		R 100%, G up, B up	136---155
		R down, G down, B 100%	156---175
		R100%G100%B100%W100%	176---195
		2800K	196---200
		3200K	201---205
		4000K	206---210
4500K	211---215		

CH-14	Color temperature	5000K	216---220
		5600K	221---225
		6500K	226--230
		7000K	231--235
		7500K	236--240
		8000K	241--255
CH-15	Macro color	No funtion	0--9
		Macro color 1	10--19
		Macro color 2	20--29
	 (10 numbers 1 macro color)
		Macro color 24	240--249
		Macro color 25	250--255
CH-16	Static pattern	No funtion	0--16
		Monochrome pattern 1	17--33
		Monochrome pattern 2	34--50
	(17 numbers 1 pattern)
		Monochrome pattern 9	153--169
		CH-16	Static pattern
Mixed color pattern 2	187--203		
Mixed color pattern 3	204--220		

		Mixed color pattern 4	221--237
		Mixed color pattern 5	238--255
CH-17	Dynamic pattern	No function	0--9
		Monochrome dynamic pattern 1	10--13
		Monochrome dynamic pattern 2	14--17
	(4 numbers 1 pattern)
		Monochrome pattern 46	190--193
		Mixed color dynamic pattern 1	194--197
		Mixed color dynamic pattern 2	198--201
	(4 numbers 1 pattern)
		Mixed color dynamic pattern 14	246--249
		Mixed color dynamic pattern 15	250--255
CH-18	Pattern movement	Choose pattern dynamic scene (with 17CH)	0-255
CH-19	Dynamic pattern speed	No function	0--9
CH-19		Forward, from fast to slow (with 17CH)	10--132
		Reverse, from slow to fast (with 17CH)	133--255
CH-20	Back color R	dark to bright linear dimming	0-255
CH-21	Back color G	dark to bright linear dimming	0-255

CH-22	Back color B	dark to bright linear dimming	0-255
CH-23	Back color W	dark to bright linear dimming	0-255
CH-24	Dimming Mode	Mode -1	0 --- 49
		Mode -2	50 --- 99
		Mode -3	100---149
		Mode -4	150---255
CH-25	Reset	No funtion	0-250
		Reset within 5s	251-255

Model 3 – CH33

Channel	Display	Function	Value
CH-1	Pan	Pan control	0 --- 255
CH-2	Pan adjustment	Pan fine adjustment	0 --- 255
CH-3	Tilt	Tilt control	0 --- 255
CH-4	Tilt adjustment	Tilt fine adjustment	0 --- 255
CH-5	Pan/Tilt speed	Speed from fast to slow	0 --- 255
CH-6	Zoom	Angle from small to large	0 --- 255
CH-7	Lens rotation	0~60°	0-155
		Clockwise infinite rotation from fast to slow	156-205

		Counterclockwise rotation from slow to fast	206-255
CH-8	Dimmer	dark to bright linear dimming	0 --- 255
CH-9	Dimmer adjustment	Dimming fine adjustment	0 --- 255
CH-10	Strobe	Turn on the light	0---3
		Synchro strobe speed From slow to fast (1HZ-25HZ)	4---203
		Random strobe	204--255
CH-11	Red	From dark to bright	0 --- 255
CH-12	Red adjustment	Red fine adjustment	0 --- 255
CH-13	Green	From dark to bright	0 --- 255
CH-14	Green adjustment	Green fine adjustment	0 --- 255
CH-15	Blue	From dark to bright	0 --- 255
CH-16	Blue adjustment	Blue fine adjustment	0 --- 255
CH-17	White	From dark to bright	0 --- 255
CH-18	White adjustment	White fine adjustment	0 --- 255
CH-19	Dimming Mode	Mode -1	0 --- 49
		Mode -2	50 --- 99

		Mode -3	100---149
		Mode -4	150---255
CH-20	Color temperature	No funtion	0 ---15
		R 100%, G up, B0%	16---35
		R down, G 100%, B0%	36---55
		R 0%, G 100%, B up	56---75
		R 0%, G down, B 100%	76---95
		R up, G 0%, B100%	96---115
		R 100%, G 0%, B down	116---135
		R 100%, G up, B up	136---155
		R down, G down, B 100%	156---175
		R100%G100%B100%W100%	176---195
		2800K	196---200
CH-20	Color temperature	3200K	201---205
		4000K	206---210
		4500K	211---215
		5000K	216---220

		5600K	221---225
		6500K	226--230
		7000K	231--235
		7500K	236--240
		8000K	241--255
CH-21	Macro color	No funtion	0--9
		Macro color 1	10--19
		Macro color 2	20--29
	(10 numbers 1 macro color)
		Macro color 24	240--249
		Macro color 25	250--255
CH-22	Static pattern	No funtion	0--16
		Monochrome pattern 1	17--33
		Monochrome pattern 2	34--50
	(17 numbers 1 pattern)
		Monochrome pattern 9	153--169
		Mixed color pattern 1	170--186

		Mixed color pattern 2	187--203
		Mixed color pattern 3	204--220
		Mixed color pattern 4	221--237
		Mixed color pattern 5	238--255
CH-23	Dynamic pattern	No function	0--9
		Monochrome dynamic pattern 1	10--13
		Monochrome dynamic pattern 2	14--17
	(4 numbers 1 pattern)
		Monochrome pattern 46	190--193
		Mixed color dynamic pattern 1	194--197
		Mixed color dynamic pattern 2	198--201
	(4 numbers 1 pattern)
		Mixed color dynamic pattern 14	246--249
		Mixed color dynamic pattern 15	250--255
CH-24	Pattern movement	Choose pattern dynamic scene (with 17CH)	0-255
CH-25	Dynamic pattern speed	No function	0--9
		Forward, from fast to slow (with 17CH)	10--132
		Reverse, from slow to fast (with 17CH)	133--255

CH-26	Pattern fade effect	Pattern effect fade	0-255
CH-27	Background dimming	Background 0-100% dimming	0-255
CH-29	Back color R	dark to bright linear dimming	0-255
CH-30	Back color G	dark to bright linear dimming	0-255
CH-31	Back color B	dark to bright linear dimming	0-255
CH-32	Back color W	dark to bright linear dimming	0-255
CH-33	Reset	No function	0-250
		Reset within 5s	251-255

Model 4– CH81

Channel	Display	Function	Value
CH-1	Pan	Pan control	0 --- 255
CH-2	Pan adjustment	Pan fine adjustment	0 --- 255
CH-3	Tilt	Tilt control	0 --- 255
CH-4	Tilt adjustment	Tilt fine adjustment	0 --- 255
CH-5	Pan/Tilt speed	Speed from fast to slow	0 --- 255
CH-6	Zoom	Angle from small to large	0 --- 255
CH-7	Lens rotation	0~60°	0-155

		Clockwise infinite rotation from fast to slow	156-205
		Counterclockwise rotation from slow to fast	206-255
CH-8	Dimmer	dark to bright linear dimming	0 --- 255
CH-9	Dimmer adjustment	Dimming fine adjustment	0 --- 255
CH-10	Strobe	Turn on the light	0---3
		Synchro strobe speed From slow to fast (1HZ-25HZ)	4---203
		Random strobe	204--255
CH-11	Red	From dark to bright	0 --- 255
CH-12	Red adjustment	Red fine adjustment	0 --- 255
CH-13	Green	From dark to bright	0 --- 255
CH-14	Green adjustment	Green fine adjustment	0 --- 255
CH-15	Blue	From dark to bright	0 --- 255
CH-16	Blue adjustment	Blue fine adjustment	0 --- 255
CH-17	White	From dark to bright	0 --- 255
CH-18	White adjustment	White fine adjustment	0 --- 255
CH-19	Dimming Mode	Mode -1	0 --- 49
		Mode -2	50 --- 99

		Mode -3	100---149
		Mode -4	150---255
CH-20	Color temperature	No funtion	0 ---15
		R 100%, G up, B0%	16---35
		R down, G 100%, B0%	36---55
		R 0%, G 100%, B up	56---75
		R 0%, G down, B 100%	76---95
		R up, G 0%, B100%	96---115
		R 100%, G 0%, B down	116---135
		R 100%, G up, B up	136---155
		R down, G down, B 100%	156---175
		R100%G100%B100%W100%	176---195
		2800K	196---200
CH-20	Color temperature	3200K	201---205
		4000K	206---210
		4500K	211---215
		5000K	216---220
		5600K	221---225
		6500K	226--230
		7000K	231--235

		7500K	236--240
		8000K	241--255
CH-21	Macro color	No funtion	0--9
		Macro color 1	10--19
		Macro color 2	20--29
		...(10 numbers 1 macro color)
		Macro color 24	240--249
		Macro color 25	250--255
CH-22	Static pattern	No funtion	0--16
		Monochrome pattern 1	17--33
		Monochrome pattern 2	34--50
	(17 numbers 1 pattern)
		Monochrome pattern 9	153--169
		Mixed color pattern 1	170--186
		Mixed color pattern 2	187--203
		Mixed color pattern 3	204--220
		Mixed color pattern 4	221--237
Mixed color pattern 5	238--255		
CH-23	Dynamic pattern	No funtion	0--9
		Monochrome dynamic pattern	10--13

		1	
		Monochrome dynamic pattern 2	14--17
	(4 numbers 1 pattern)
		Monochrome pattern 46	190--193
		Mixed color dynamic pattern 1	194--197
		Mixed color dynamic pattern 2	198--201
	(4 numbers 1 pattern)
		Mixed color dynamic pattern 14	246--249
		Mixed color dynamic pattern 15	250--255
CH-24	Pattern movement	Choose pattern dynamic scene (with 23CH)	0-255
CH-25	Dynamic pattern speed	No function	0--9
		Forward, from fast to slow (with 23CH)	10--132
		Reverse, from slow to fast (with 23CH)	133--255
CH-26	Pattern fade effect	Pattern effect fade	0-255
CH-27	Background dimming	Background 0-100% dimming	0-255
CH-29	Back color R	dark to bright linear dimming	0-255
CH-30	Back color G	dark to bright linear dimming	0-255

CH-31	Back color B	dark to bright linear dimming	0-255
CH-32	Back color W	dark to bright linear dimming	0-255
CH-33	Reset	No funtion	0-250
		Reset within 5s	251-255
CH-34	R1 LED dimming	R1 LED dimming	0-255
CH-35	G1 LED dimming	G1 LED dimming	0-255
CH-36	B1 LED dimming	B1 LED dimming	0-255
CH-37	W1 LED dimming	W1 LED dimming	0-255
.....
CH-78	R12 LED dimming	R12 LED dimming	0-255
CH-79	G12LED dimming	G12 LED dimming	0-255
CH-80	B12LED dimming	B12 LED dimming	0-255
CH-81	W12LED dimming	W12 LED dimming	0-255

4.LUXDate

Beam Angle = 3.5°

R lux	15300	10100	4300	1620
G lux	33400	23400	9300	3520
B lux	6490	4520	1700	643
W lux	42300	29200	11900	4530
4in1 lux	86900	59700	24300	9200

Beam Angle = 45°

R lux	5130	635	215	88
G lux	11300	1340	499	198
B lux	2170	259	99	38
W lux	14100	1760	585	241
4in1 lux	29400	3690	1230	507

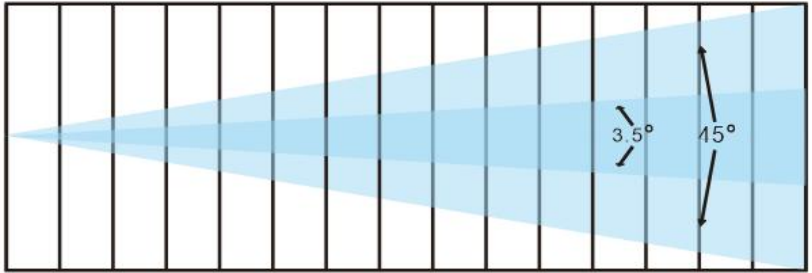

Distance (m)

Spot diameter (m) 3.5°

Spot diameter (m) 45°

1

3

5

8

0.32

0.62

0.83

1.14

1.10

2.80

4.33

5.Shape

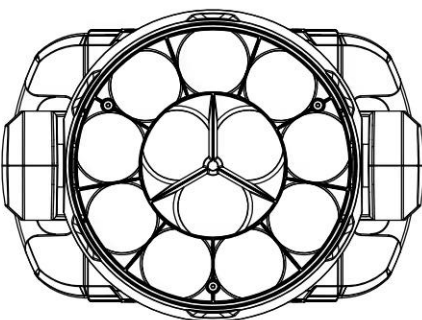
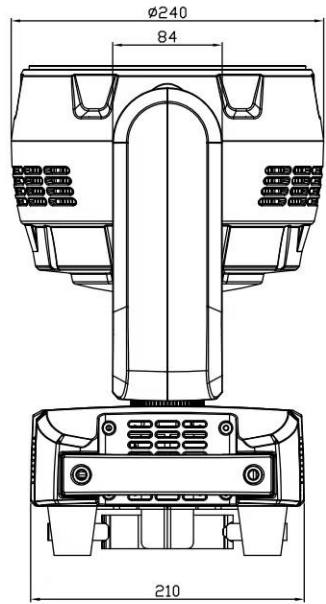
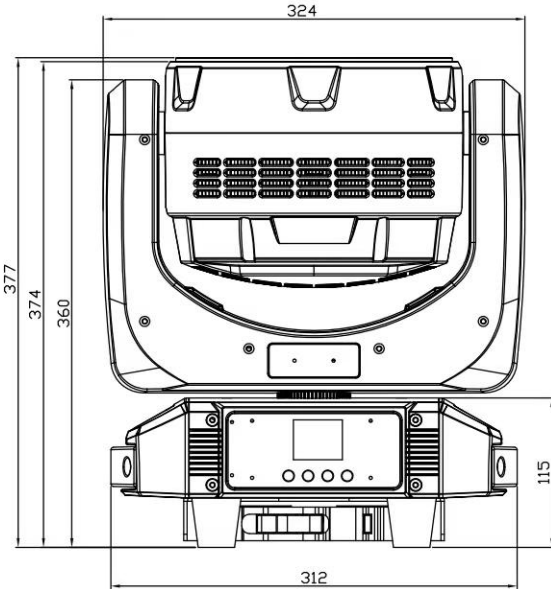

6. Trouble shooting

Following are a few common problems that may occur during operation. Here are some suggestions for easy troubleshooting:

A. The unit does not work, no light and the fan does not work

1. Check the connection of power and main fuse.
2. Measure the mains voltage on the main connector.
3. Check the power on LED.

B. Not responding to DMX controller

1. DMX LED should be on. If not, check DMX connectors, cables to see if link properly.
2. If the DMX LED is on and no response to the channel, check the address settings and DMX polarity.
3. If you have intermittent DMX signal problems, check the pins on connectors or on PCB of the unit or the previous one.
4. Try to use another DMX controller.
5. Check if the DMX cables run near or run alongside to high voltage cables that may cause damage or interference to DMX interface circuit.

C. One of the channels is not working well

1. The stepper motor might be damaged or the cable connected to the PCB is broken.
2. The motor's drive IC on the PCB might be out of condition.

6. Fixture Cleaning

The cleaning of internal and external optical lenses and/or mirrors must be carried out periodically to optimize light output. Cleaning frequency depends on the environment in which the fixture operates: damp, smoky or particularly dirty

surrounding can cause greater accumulation of dirt on the unit's optics.

- **Clean with soft cloth using normal glass cleaning fluid.**
- **Always dry the parts carefully.**
- **Clean the external optics at least every 20 days. Clean the internal optics at least every 30/60 days.**