

12*4in1 40w wash zoom moving head

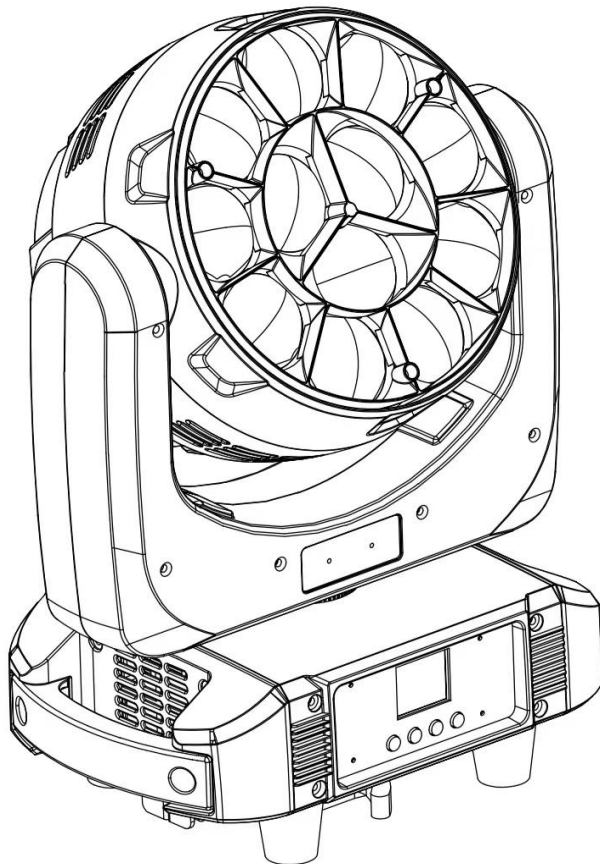

User manual

Please read the instructions carefully before use

TABLE OF CONTENTS

1. Safety Instructions	3-4
2. Technical Specifications	5
3. How To Control The Unit	6-12
4. shape	15
5. Trouble shooting	14
6. Fixture Cleaning	17

statement

The product has well capability and intact packing when leave factory. All of the user should comply with warning item and manual, any misuse cause of the damages are not included in our guarantee, and also can't be responsible for any malfunction & problem owing to ignore the manual.

1. Safety Instructions

Please keep this User Guide for future consultation. If you sell the unit to another user, be sure that they also receive this instruction booklet.

- ⊠ Unpack and check carefully there is no transportation damage before using the unit.
- ⊠ Before operating, ensure that the voltage and frequency of power supply match the power requirements of the unit.
- ⊠ It's important to ground the yellow/green conductor to earth in order to avoid electric shock.
- ⊠ The unit is for indoor use only. Use only in a dry location.
- ⊠ The unit must be installed in a location with adequate ventilation, at least 50cm from adjacent surfaces. Be sure that no ventilation slots are blocked.
- ⊠ Disconnect main power before replacement or servicing.

- ⊠ Make sure there are no flammable materials close to the unit while operating as it is fire hazard.
- ⊠ Use safety cable when fixes this unit. Do not handle the unit by taking its head only, but always by taking its base.

- ⊠ Maximum ambient temperature is T_a : 40°C. Do not operate it where the temperature is higher than this Unit surface temperature may reach up to 85°C. Do not touch the housing bare-hand during its operation. Turn off the power and allow about 15 minutes for the unit to cool down before replacing or serving.

- ⊠ In the event of serious operating problem, stop using the unit immediately. Never try to repair the unit by yourself. Repairs carried out by unskilled people can lead to damage or malfunction. Please contact the nearest authorized technical assistance center. Always use the same type spare

parts.

⚠ Do not touch any wire during operation as high voltage might be causing electric shock.

Warning:

- ⚠ To prevent or reduce the risk of electrical shock or fire, do not expose the unit to rain or moisture.
- ⚠ Do not open the unit within five minutes after switching off.
- ⚠ The housing, the lenses, or the ultraviolet filter must be replaced if they are visibly damaged.

Caution:

There are no user serviceable parts inside the unit. Do not open the housing or attempt any repairs yourself. In the unlikely event your unit may require service, please contact your nearest dealer.

Installation:

The unit should be mounted via its screw holes on the bracket. Always ensure that the unit is firmly fixed to avoid vibration and slipping while operating. And make sure that the structure to which you are attaching the unit is secure and is able to support a weight of 10 times of the unit's weight. Also always use a safety cable that can hold 12 times of the weight of the unit when installing the fixture.

The equipment must be fixed by professionals. And it must be fixed at a place where is out of the touch of people.

2. Technical Specifications

Light Sources: 12 x 40W 4in1 RGBW LED

Beam Angle: 3.5°~ 45°

Power Consumption: 380W

Power Voltage: AC 100-240V, 50/60Hz

Dimension: 324x240x377mm

Net Weight: 9Kgs

Packing size: 400x310x430mm

Control

DMX Channel: 16/21 Channel

Control Modes: DMX512/master-Slave/Auto Run/Music

Pan/Tilt

Pan/Tilt: 540°or 360° in optional / 270°

Pan/Tilt Resolution: 8/16 bit

Construction

Display: 1.8 TFT colorful Display

Data In/Out socket: 3-pin & 5-pin XLR sockets

Power Socket: PowerCon in/out

Protection Rating: IP20

Features

Motorized liner zoom system, zoom range: 3.5°~45°

Outstanding color macro effect

Dimmer: 0~100% smooth dimming

Variable strobe effects

Fast, quiet operation and flicker free

3. How To Control The Unit

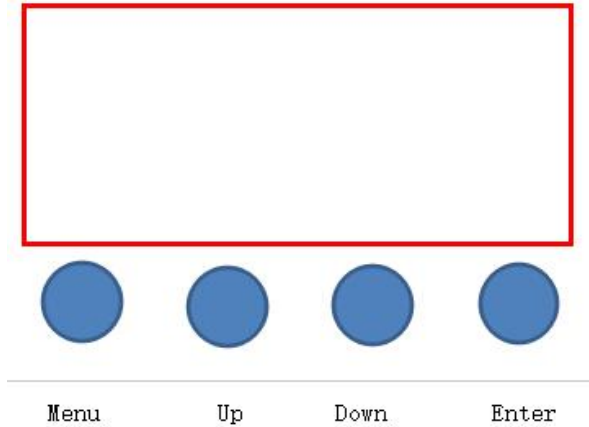

Display:

- MENU To select the programming functions
- DOWN To go backward in the selected functions
- UP To go forward in the selected functions
- ENTER To confirm the selected functions

Set DMX Address Code

- 1 Press "**Menu**" to "Set DMX Address", and press "**ENTER**" keys to enter into
- 2 Show "Set DMX Address DMX Address:**001**", Press the "**UP and DOWN**" keys to amended
- 3 Press "**ENTER**" keys to save and Exit, Press the "**MENU**" Keys does not save and Exit

Menu	1.Pan Degree	1.540	
		2.360	
	2.Mic Sense	001--100	Sound control adjust sensitiveness
	3.Language	1.English	

		2.Chinese
4.No Signal		1.Black Out
		2.Hold
5. Fan Set		1. Auto
		2. Low
		3. High
6.Reset		1.Yes
		2.No
9.Default		1.Yes
		2.No
10.Adjust	Pass Word	****
	1.Pan	Pan fine-adjust
	2.Tilt	Tilt fine-adjust
	3.Focus	Zoom fine-adjust
	4.Rota: 0-255	Rota fine-adjust
	5.Red	Change the value, adjust the white balance
	6.Green	
	7.Blue	
	8.White	
Address	Set address code 001--512	
Reverse	1.Pan	1.Yes
		2.No
	2.Tilt	1.Yes
		2.No
	3.Display	1.Yes

		2.No	
Inform	1.CH Value		display all channel values
	2.Temp/°C		display led board temperature
	3.Soft v.xxx		software version number
Mode	1.DMX512		
	2.Auto		1.Master
			2.Alone
	3.Sound		1.Master
			2.Alone
	4.Manual	Master	1.Pan:0--255
			2.Tilt:0--255
			3.Focus) :0--255
			4.Red: 0--255
		Alone	5.Greed: 0--255
6.Bule: 0--255			
7.White: 0--255			
8. Strobe: 0-255			
Channel	1.16Channels		
	2.21Channels		

**DMX channel's functions and values (16/21DMX channels):
Model 1 - CH16**

Channel	Display	Function	Value
CH-1	Pan	Pan control	0 --- 255
CH-2	Pan adjustment	Pan adjustment	0 --- 255
CH-3	Tilt	Tilt control	0 --- 255
CH-4	Tilt adjustment	Tilt adjustment	0 --- 255
CH-5	Pan/Tilt speed	from fast to slow	0 --- 255
CH-6	Zoom	from small to big	0 --- 255
CH-7	Dimming	From dark to bright	0 --- 255
CH-8	Strobe	No	0 --- 3
		From slow to fast	4 --- 203
		Random strobe	204 --- 255
CH-9	Red	From dark to bright	0 --- 255
CH-10	Green	From dark to bright	0 --- 255
CH-11	Blue	From dark to bright	0 --- 255
CH-12	White	From dark to bright	0 --- 255
CH-13	Dimming Model	Model -1	0 --- 49
		Model -2	50 --- 99

		Model -3	100 --- 149
		Model -4	150 --- 255
CH-14	Color temperature	No	0----15
		R 100%, G up, B0%	16----35
		R down, G 100%, B0%	36----55
		R 0%, G 100%, B up	56----75
		R 0%, G 100%, B up	76----95
		R up, G0%, B 100%	96----115
		R 100%, G 0%, B down	116----135
		R 100%, G up, B up	136----155
		R down, G down, B100%	156----175
		R100%G100%B100%W100%	176----195
		2800K	196----200
		3200K	201----205
		4000K	206----210
		4500K	211----215
		5000K	216----220
		5600K	221----225
		6500K	226----230
7000K	231----235		

		7500K	236----240
		8000K	241----255
CH-15	Macro Color	No	0 --- 15
		Zone -1	16-- 31
		Zone -2	32-- 47
		16 numbers 1 effect
		Zone -14	224 --- 239
		Zone -15	240 --- 255
CH-16	Reset	No	0 --- 250
		Reset	250- 255

Model 2 – CH21

Channel	Display	Function	Value
CH-1	Pan	Pan control	0 --- 255
CH-2	Pan adjustment	Pan adjustment	0 --- 255
CH-3	Tilt	Tilt control	0 --- 255
CH-4	Tilt adjustment	Tilt adjustment	0 --- 255
CH-5	Pan/Tilt speed	from fast to slow	0 --- 255

CH-6	Zoom	from small to big	0 --- 255
CH-7	Dimming	From dark to bright	0 --- 255
CH-8	Dimming adjustment	Dimming adjustment	0 --- 255
CH-9	Strobe	No	0 --- 3
		From slow to fast	4 --- 203
		Random strobe	204 --- 255
CH-10	Red	From dark to bright	0 --- 255
CH-11	Red adjustment	Red adjustment	0 --- 255
CH-12	Green	From dark to bright	0 --- 255
CH-13	Green adjustment	Green adjustment	0 --- 255
CH-14	Blue	From dark to bright	0 --- 255
CH-15	Blue adjustment	Blue adjustment	0 --- 255
CH-16	White	From dark to bright	0 --- 255
CH-17	White adjustment	White adjustment	0 --- 255
CH-18	Dimming Model	Model -1	0 --- 49
		Model -2	50 --- 99
		Model -3	100 --- 149
		Model -4	150 --- 255

CH-19 Color Temperature	No	0----15
	R 100%, G up, B0%	16----35
	R down, G 100%, B0%	36----55
	R 0%, G 100%, B up	56----75
	R 0%, G100%, B up	76----95
	R up, G 0%, B100%	96----115
	R 100%, G 0%, B down	116----135
	R 100%, G up, B up	136----155
	R down, G down, B 100%	156----175
	R100%G100%B100%W100%	176----195
	2800K	196----200
	3200K	201----205
	4000K	206----210
	4500K	211----215
	5000K	216----220
	5600K	221----225
	6500K	226----230
	7000K	231----235
	7500K	236----240
	8000K	241----255

CH-20	Macro Color	No	0 --- 15
		Effect -1	16-- 31
		Effect -2	32-- 47
		16 numbers 1 effect
		Effect -14	224 --- 239
		Effect -15	240 --- 255
CH-21	Reset	No	0 --- 250
		Reset	250- 255

4.LUX Data

Beam Angle = 3.5°

R lux	17200	4820	2110	888
G lux	38400	10800	4730	2060
B lux	2530	2010	925	423
W lux	46500	12900	5800	2500
4in1 lux	100000	28000	12600	5510

Beam Angle = 45°

R lux	5590	580	222	91
G lux	12800	1250	496	201
B lux	2510	245	97	39
W lux	15500	1540	593	241
4in1 lux	34300	3340	1300	532

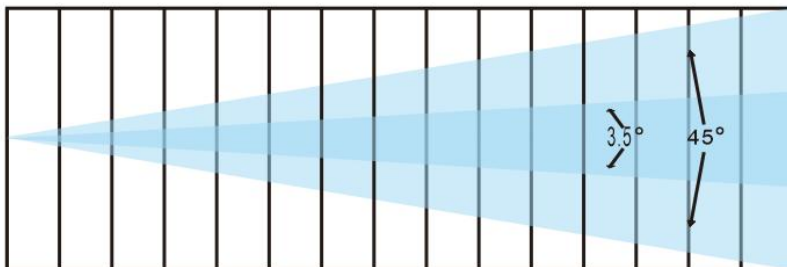

Distance (m)	1	3	5	8
Spot diameter (m) 3.5°	0.32	0.73	1.15	1.76
Spot diameter (m) 45°	1.13	3.30	4.40	

5.Shape

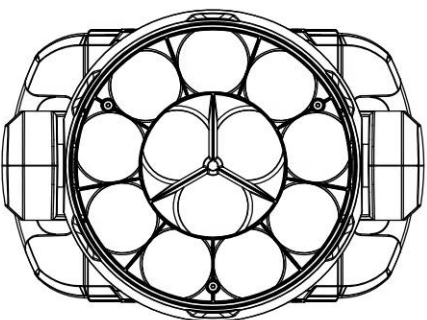
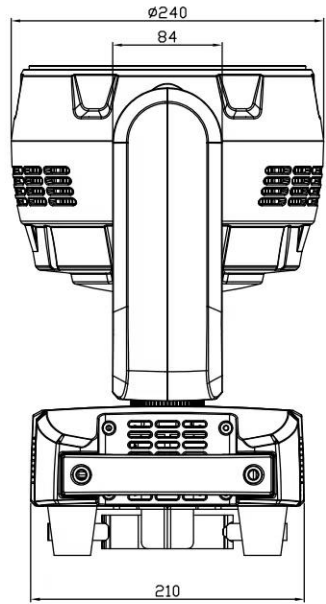
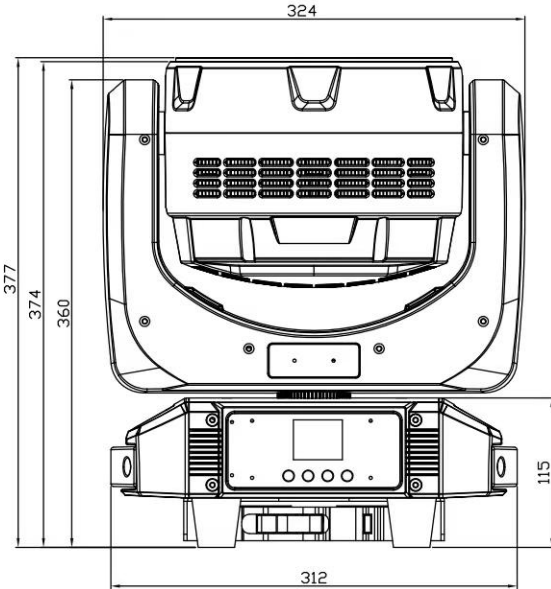

6. Trouble shooting

Following are a few common problems that may occur during operation. Here are some suggestions for easy troubleshooting:

A. The unit does not work, no light and the fan does not work

1. Check the connection of power and main fuse.
2. Measure the mains voltage on the main connector.
3. Check the power on LED.

B. Not responding to DMX controller

1. DMX LED should be on. If not, check DMX connectors, cables to see if link properly.
2. If the DMX LED is on and no response to the channel, check the address settings and DMX polarity.
3. If you have intermittent DMX signal problems, check the pins on connectors or on PCB of the unit or the previous one.
4. Try to use another DMX controller.
5. Check if the DMX cables run near or run alongside to high voltage cables that may cause damage or interference to DMX interface circuit.

C. One of the channels is not working well

1. The stepper motor might be damaged or the cable connected to the PCB is broken.
2. The motor's drive IC on the PCB might be out of condition.
6. Fixture Cleaning

The cleaning of internal and external optical lenses and/or mirrors must be carried out periodically to optimize light output. Cleaning frequency depends on the environment in which the fixture operates: damp, smoky or particularly dirty surrounding can cause greater accumulation of dirt on the unit's optics.

- **Clean with soft cloth using normal glass cleaning fluid.**
- **Always dry the parts carefully.**

- **Clean the external optics at least every 20 days. Clean the internal optics at least every 30/60 days.**